

# Thermostatic Dialysis Station



**WARNING:** This product can expose you to chemicals including lead, which is known to the State of California to cause cancer. For more information, go to [www.P65Warnings.Ca.gov](http://www.P65Warnings.Ca.gov)

Valve assembly is certified to meet Low-Lead requirements of wetted surface area containing less than 0.25% lead by weight. All other fittings and components, the sum total of which comprise the wetted surface of this product contains less than one quarter of one percent of lead by weight.

**CAUTION!** All thermostatic water-mixing valves have limitations. They will NOT provide the desired accuracy outside of their flow capacity range. Consult the Flow Capacity Chart and DO NOT OVERSIZE. Minimum flow must be no less than as indicated.

**\*NOTE:** A limit stop, set for 120°F (49°C), is simply a mechanical setting to prevent excessive handle rotation. If incoming water is hotter than 150°F (65.5°C), the temperature of the factory test, the valve when turned to full HOT may deliver water in excess of 120°F and the limit stop MUST BE RESET BY THE INSTALLER

**Engineer's Approval**

Job # \_\_\_\_\_

Arch/Eng. \_\_\_\_\_

Contractor \_\_\_\_\_

## ECO-MIX™

### THERMOSTATIC MIXING STATION FOR DIALYSIS APPLICATIONS

#### OR-1776A-LF

Thermostatic Mixing Valve Station for Dialysis Applications. This special system provides controlled low flow water temperature for dialysis using a Leonard TAP thermostatic water mixing valve, powered by the DURA-trol® solid bimetal thermostat. The mixed water outlet assembly includes an atmospheric vacuum breaker, dial thermometer, ¼ turn ball valve and quick coupler with dust cover. The unit is mounted in a type 316 stainless steel cabinet with flange and panel for the mixing valve assembly. The unit is factory assembled and tested by the Leonard Valve Company, Cranston, RI.

#### OR-1776A-LF 1/2" inlets and outlet

- TAP Thermostatic water mixing valve
- Dura-trol® solid bimetal thermostat directly linked to valve porting to control the intake of hot and cold water and compensate for supply temperature or pressure fluctuations. Dura-trol® is highly responsive and cannot be damaged by extremes in temperature
- Adjustable high temperature limit stop set for 110°F \* (43°C)
- Maximum operation pressure: 125 PSI (860 KPA)
- Temperature selector handle with scale: COLD-HOT
- Combination angle checkstops on inlets, wall support
- Outlet vacuum breaker (atmospheric type), dial thermometer (25-125°F, 0-50°C), ¼ turn ball valve, quick coupler with dust cover
- Stainless steel cabinet (type 316) with rounded corners, 4" depth, 2" waste, and face panel attached to cabinet tabs with vandal resistant screws.
- Top supply, ½" stainless flex hose
- Factory assembled and tested

#### OPTIONS

- Back Inlet Connection
- Left Side Inlet Connection
- Right Side Inlet Connection
- Turn latch

Product is non-cancellable and non-returnable from date from order with factory. Signed submittal required with purchase order.

1360 Elmwood Avenue, Cranston, RI 02910 USA

Phone: 401.461.1200 Fax: 401.941.5310

Email: [info@leonardvalve.com](mailto:info@leonardvalve.com)

Web Site: <http://www.leonardvalve.com>

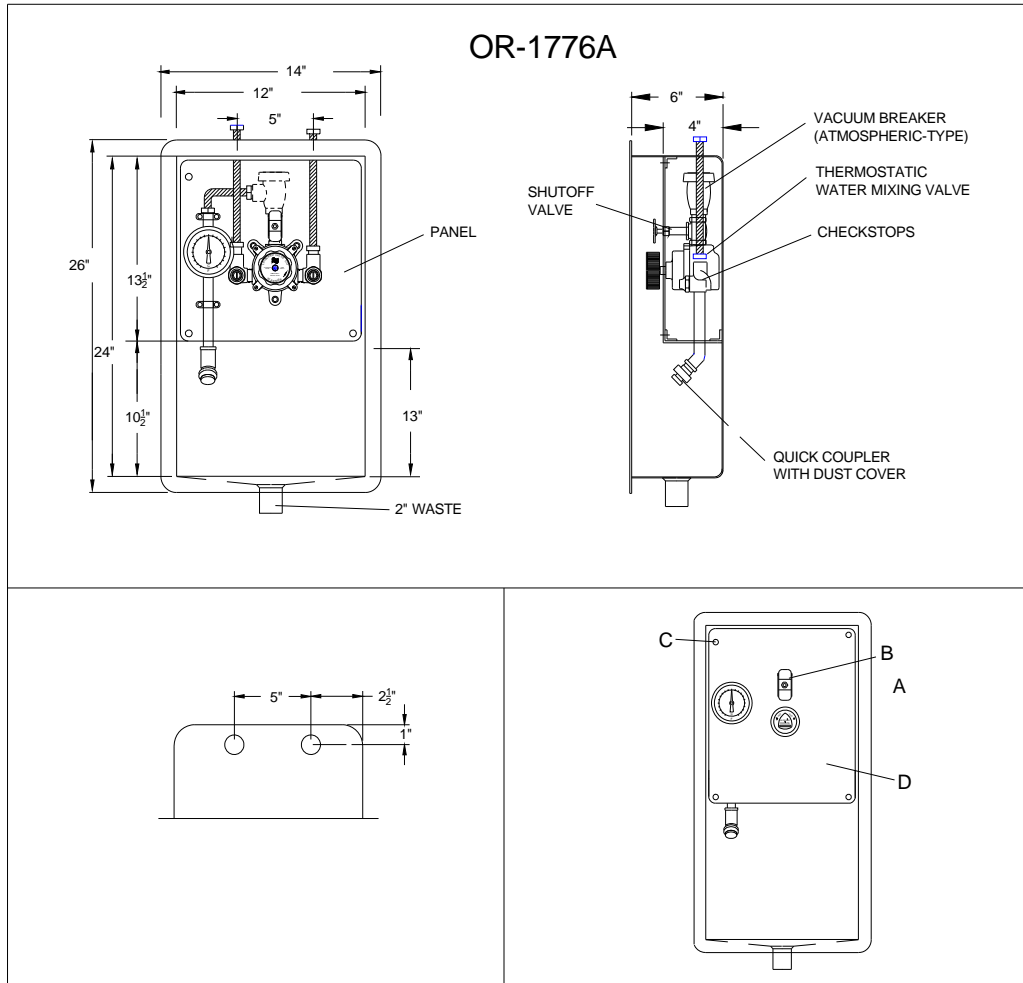

TO SERVICE VALVE

- A) REMOVE SCREW ON SIDE OF TEMPERATURE ADJUSTING REGULATING KNOB
- B) REMOVE NUT ON TOP OF VOLUME CONTROL HANDLE, AND REMOVE
- C) REMOVE 4 VANDAL PROOF PANEL SCREWS, AND REMOVE PANEL
- D) REMOVE PANEL

### FLOW CAPACITIES

MODEL	IN	OUT	MINIMUM FLOW (GPM)	SYSTEM PRESSURE DROP							PSI
				5	10	20	30	40	45	50	
			LMIN	.3	.7	1.4	2.1	2.8	3.1	3.4	BAR
OR-1776A	1/2"	1/2"	0.5	2.0	4.0	5.5	7.0	8.0	8.5	9.0	GPM
			1.9	7.6	15	21	26	30	32	34	LMIN



1360 Elmwood Avenue, Cranston, RI 02910 USA

Phone: 401.461.1200 Fax: 401.941.5310

Email: [info@leonardvalve.com](mailto:info@leonardvalve.com)

Web Site: <http://www.leonardvalve.com>